

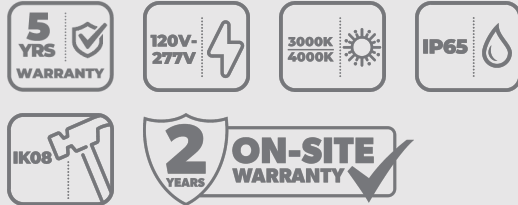

GUARD BOLLARD

ARCHITECTURAL BOLLARDS

Guard Architectural Bollards are stylish and robust. Available in 4 interchangeable heads. Ideal for walkways, entrance ways, drives and other small-area lighting applications where low mounting heights are desirable.



Features

- Attractive architectural Design
- Selectable Power
- CCT Selectable
- 5 Year Warranty
- Durable powder coat finish

Specification

Code	Description	Lumen Output	Emergency Lumen Output	Wattage	Efficacy
GRD24A-DL-CCT	Guard Bollard Dome Head Louvre Anthracite 24W 2CCT	1092lm 1482lm 1870lm		14W 19W 24W	78 lm/w

Product Information

Warranty	5 Years
On-Site Warranty	2 Years
Colour Appearance (CCT)	3000K 4000K
IP Rating	IP65
IK Rating	IK08
Voltage	120-277V
Material (Body/Housing)	Aluminium
Material (Diffuser/Cover)	Polycarbonate
Colour Rendition (CRI)	Ra >70

Colour Finish	Anthracite RAL7016
LED Life Expectancy	L70B50 54,000 Hours
Power Factor	0.9
Frequency	50/60Hz
Driver Type	Fixed
Approval	UKCA CE
Electrical Class	Class I
Working Temperature	-20°C to 50°C



GUARD BOLLARD

ARCHITECTURAL BOLLARDS

Packaging Information

Dimensions (mm)	L: 210 X W: 160 Ø
Product Net Weight (kg)	2.44 kg
Barcode	5055807626255
Box Dimensions (mm)	L: 205 x W:205 x D: 385 mm
Box Gross Weight (kg)	2.76 kg

Units/Outer Carton	4
Outer Carton Barcode	15055807626252
Outer Carton Dimensions (mm)	L: 430 x W: 430 x D: 405 mm
Outer Carton Gross Weight (kg)	11.5 kg

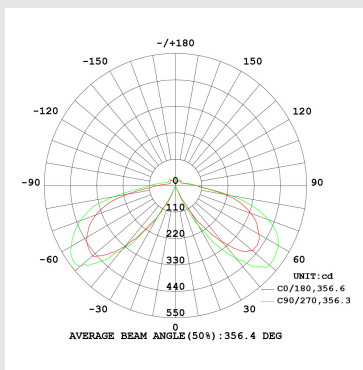
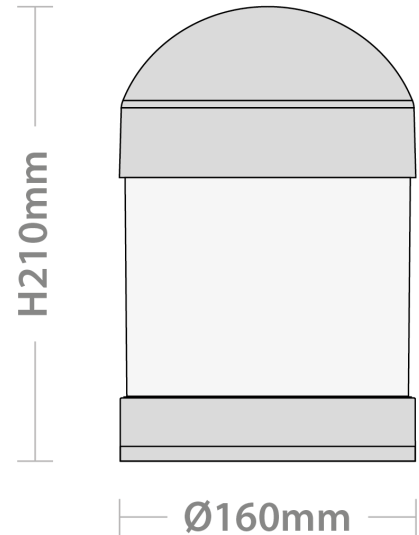

ENERGY
 Red Arrow
 Louvre Head

A
 B
 C
 D
 E
 F
 G

24
 kWh/1000h